

Bracing Instructions.

(AB Angled Type)

10.23

Supplied Parts:-

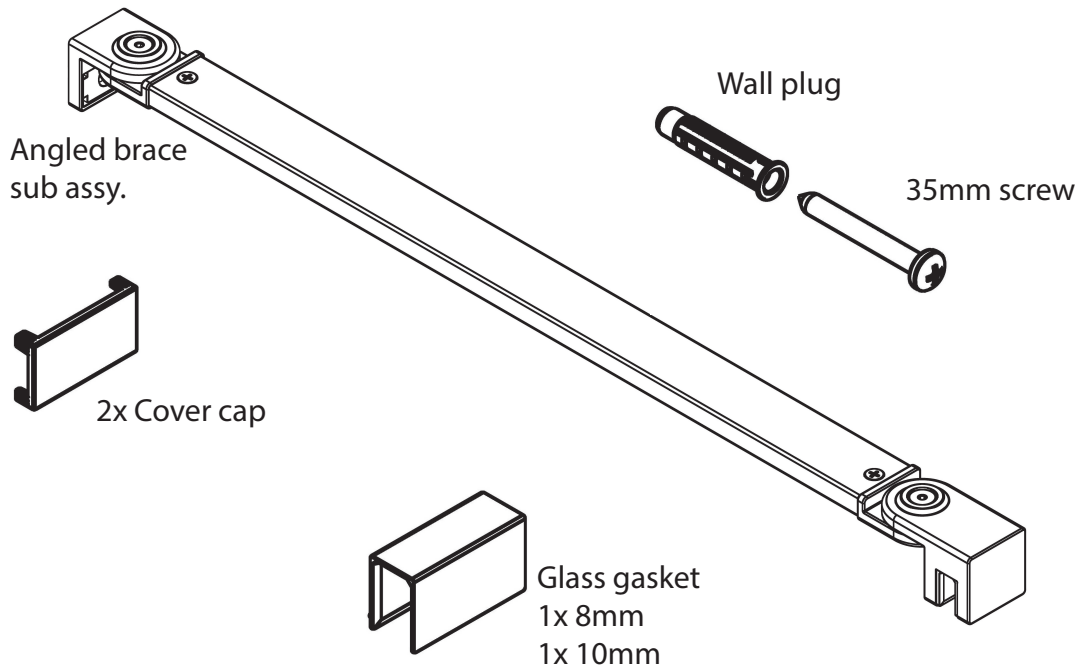

1. Select correct gasket for glass thickness and fit into glass clamp.
2. If required, slightly loosen screws holding glass clamp & wall bracket to bracing bar to allow angle adjustment.
3. Offer bracing assembly onto glass panel and adjust to required angle (45° is optimal). Ensure bar is level then mark fixing position through wall bracket. Remove bracing assembly then drill marked position with 6mm tile / masonry bit & fit wall plug.

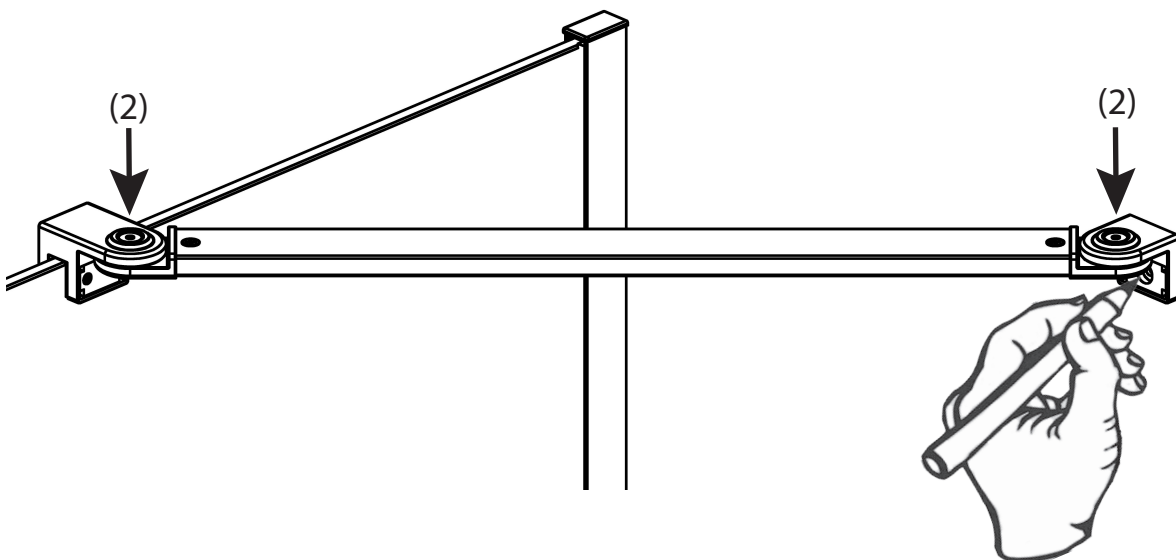

4. Place bracing assembly onto glass and fix to wall using M4 x 35mm screw.
5. Tighten grub screws on glass clamp.
6. Tighten screws holding glass clamp & wall bracket to bracing bar to fix bracing angle.

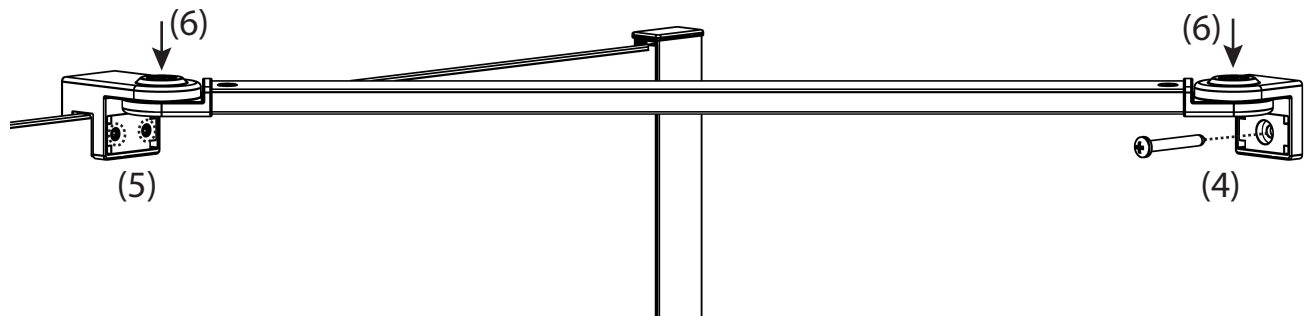

7. Fit screw covers to glass clamp & wall bracket

