

Bracing Instructions.

(BB3 Fixed Bypass Type)

10.23

Parts Supplied:-

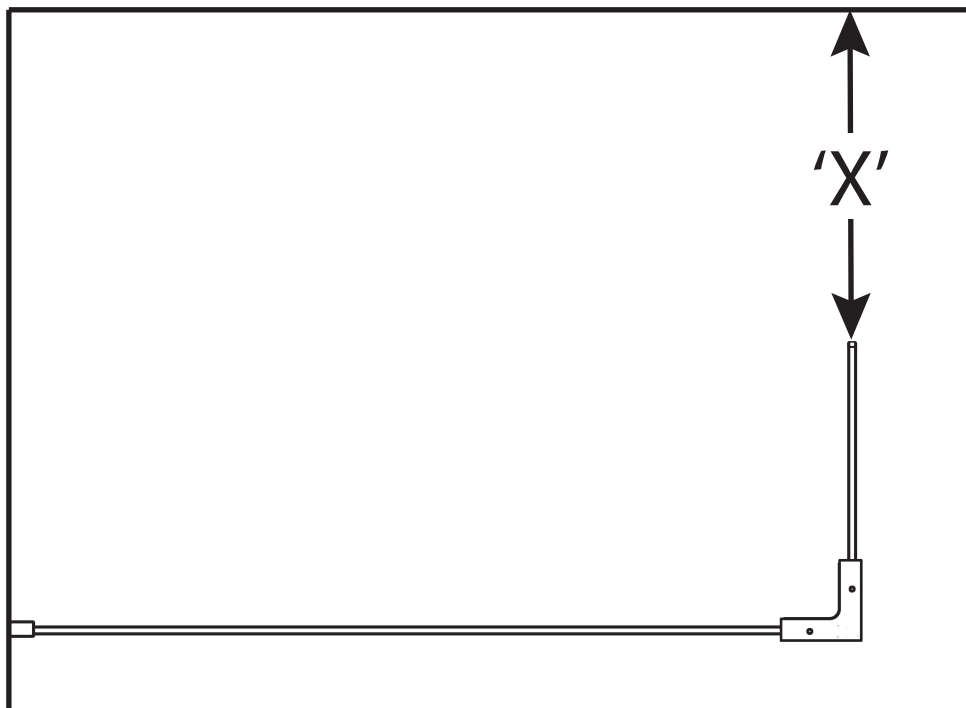
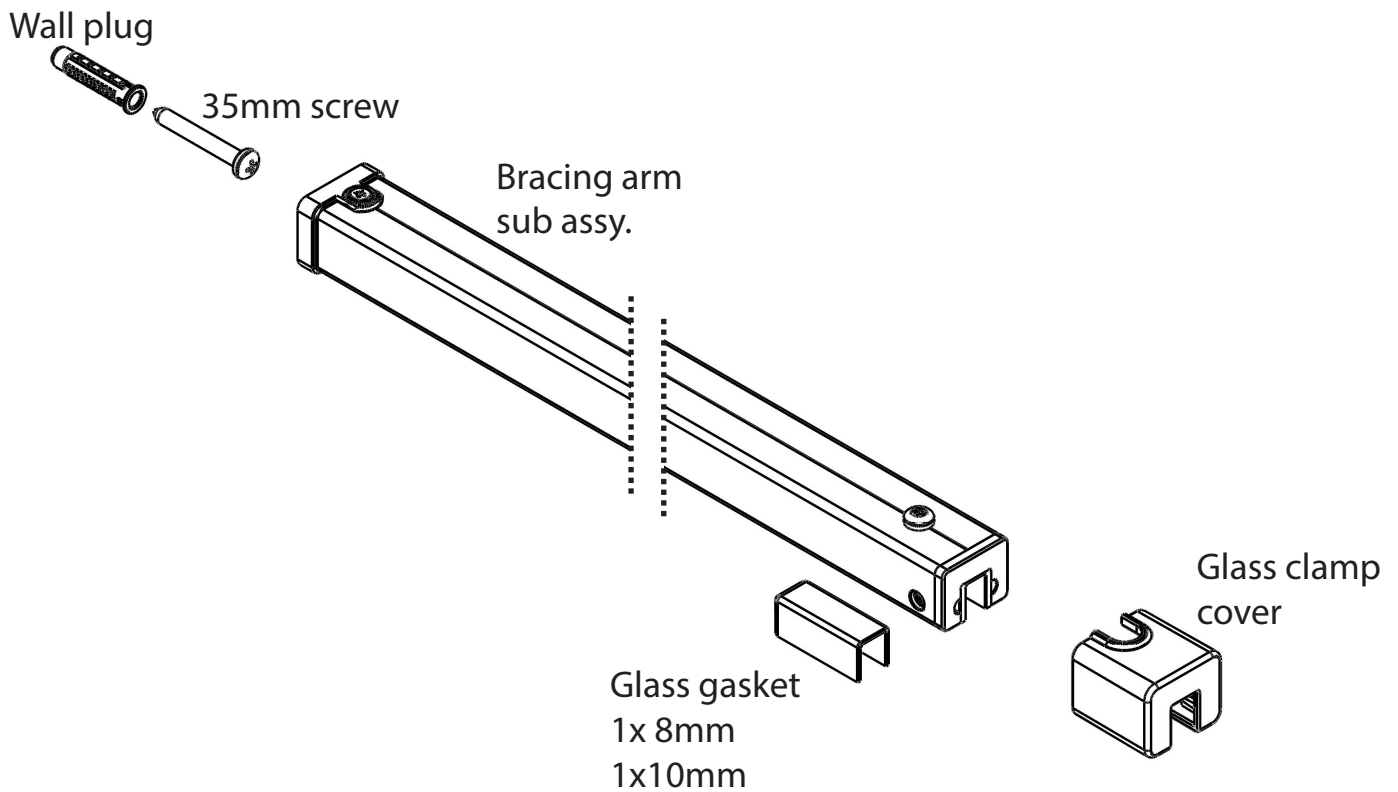

1. Ensure Plumb then measure from end of fixed bypass panel to back wall (X). Remove wall bracket from bracing assembly.

Cut this end ONLY!

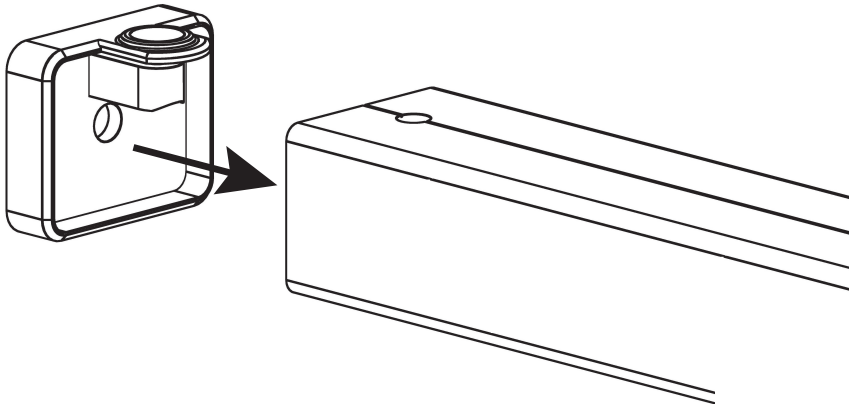
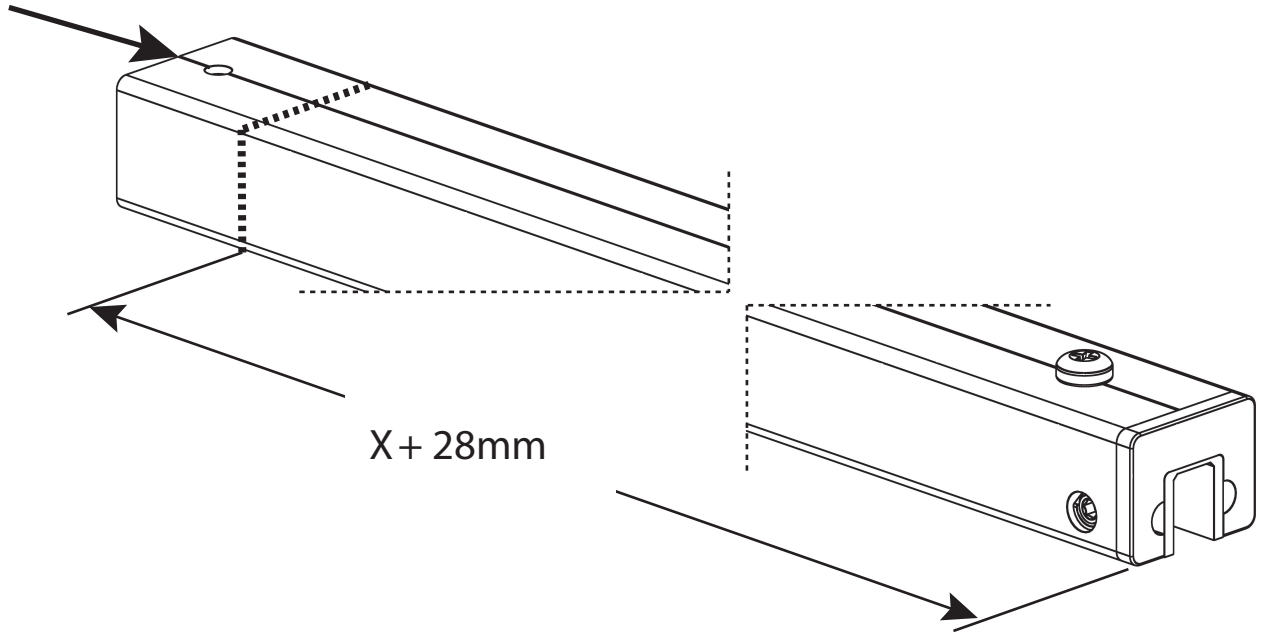

2. Place wall bracket onto cut end of bracing bar.

3. With wall bracket pushed fully onto bracing bar, mark through hole on top of wall bracket. Remove wall bracket then drill marked position with 3,5mm bit

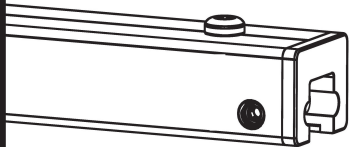
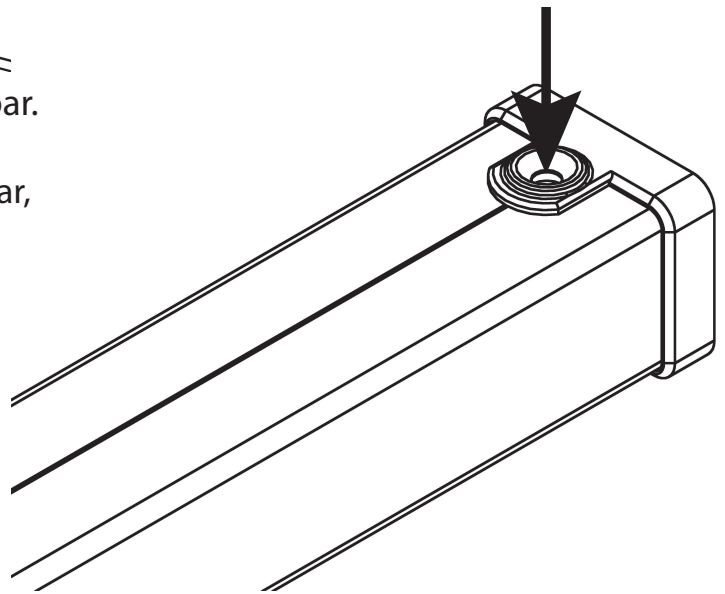

4. Select correct gasket for glass thickness, fit into bracing arm clamp then offer assembly onto top of bypass panel glass.

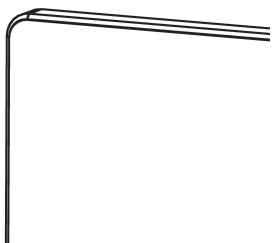

5. Ensure bracing arm is level, mark wall bracket position. Remove bracing arm..

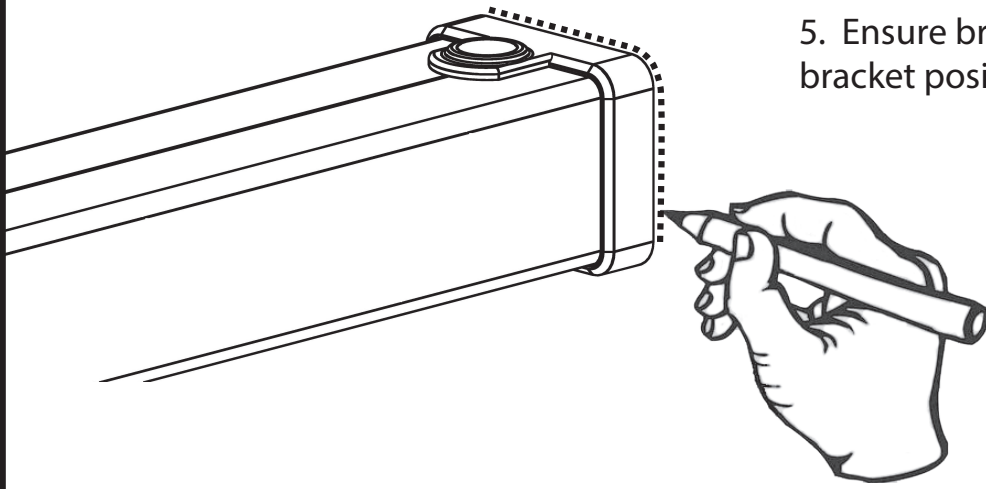

6. Remove wall bracket from assembly then offer it onto wall in marked position. Mark centre hole position on wall. Drill with 6mm tile / masonry bit. Fit wall plug.

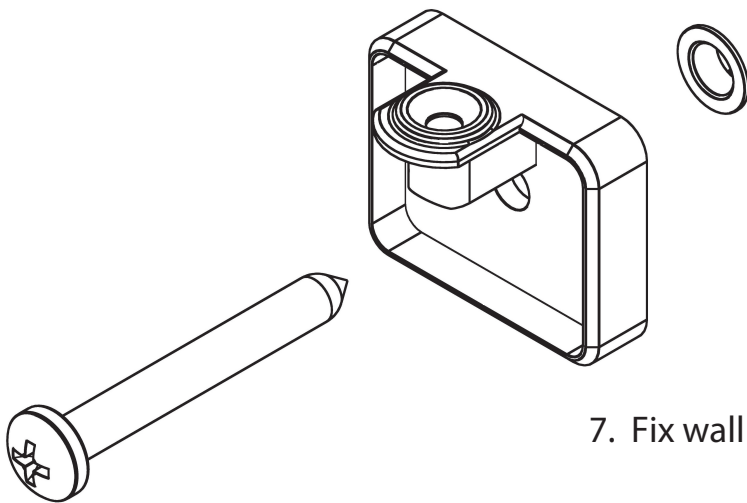
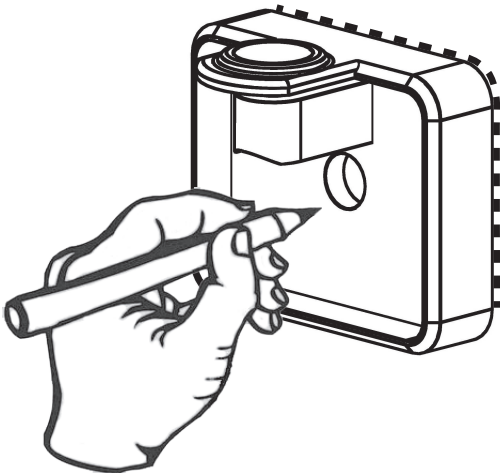

7. Fix wall bracket to wall Using M4 x 35mm screw.

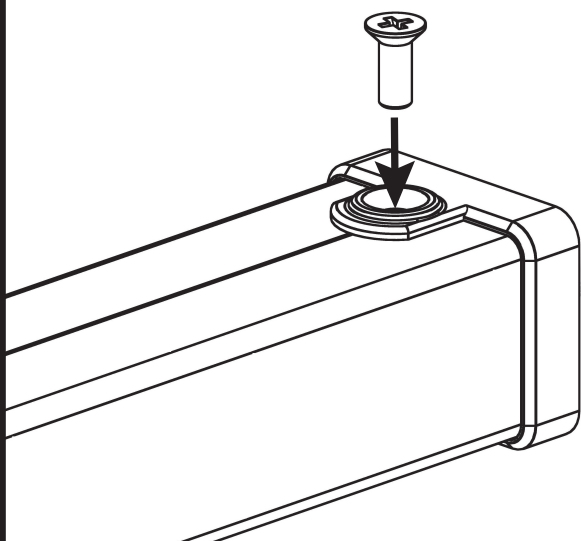

8. Carefully insert bar end into wall bracket & clamp end onto glass. Fix bar to wall bracket with M3 screw.

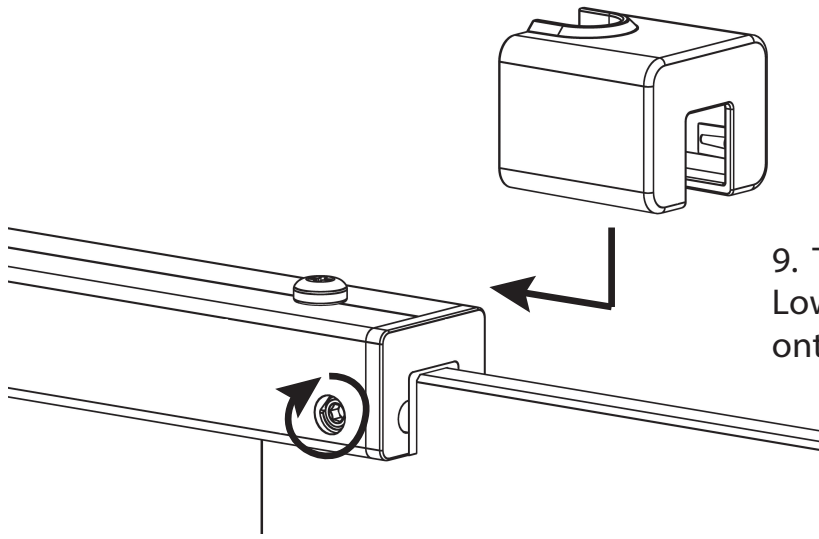

9. Tighten grubscrew in side of glass clamp. Lower clamp cover onto glass top and push onto bracing bar end.

Side Panel Bracing (BB1**).

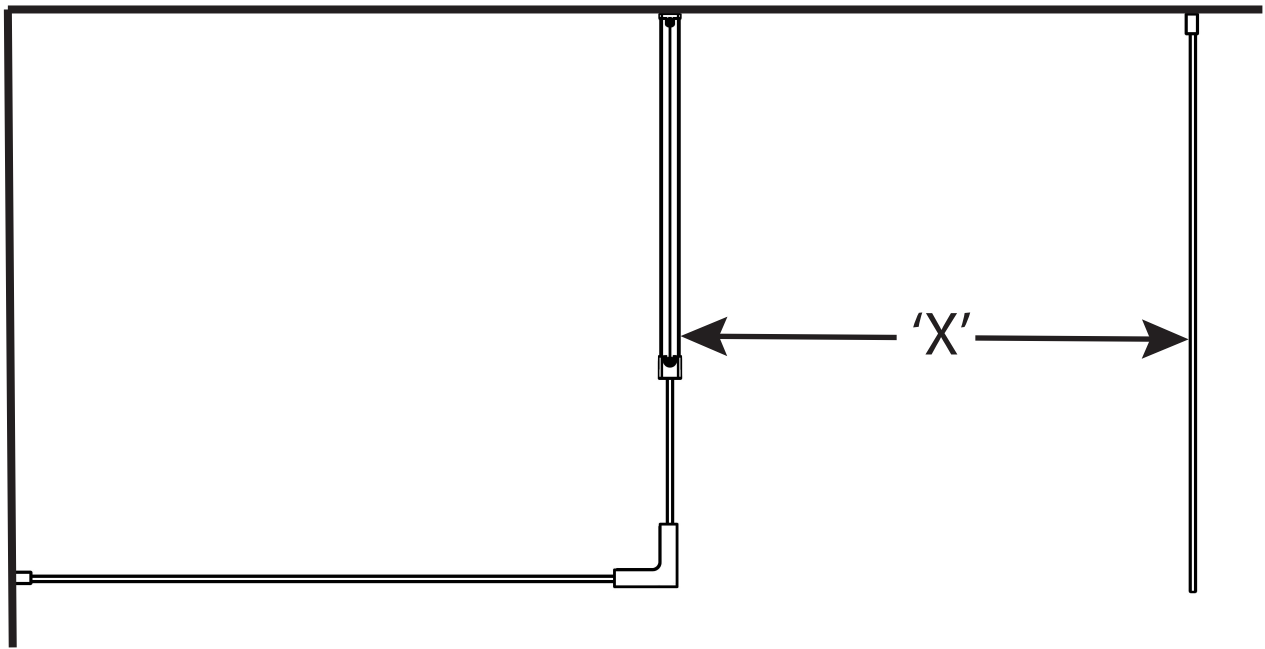

After fitting fixed bypass bracing arm.

Measure from fixed bracing arm to inside of side panel glass (X). With clamping mechanism pushed fully into bar, remove wall bracket & cut side panel bracing bar to :

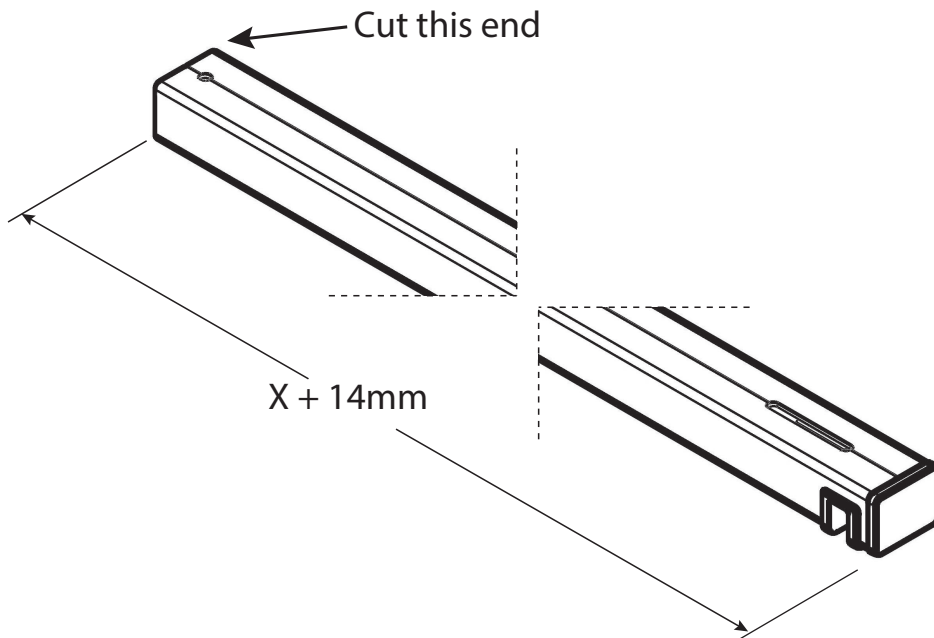

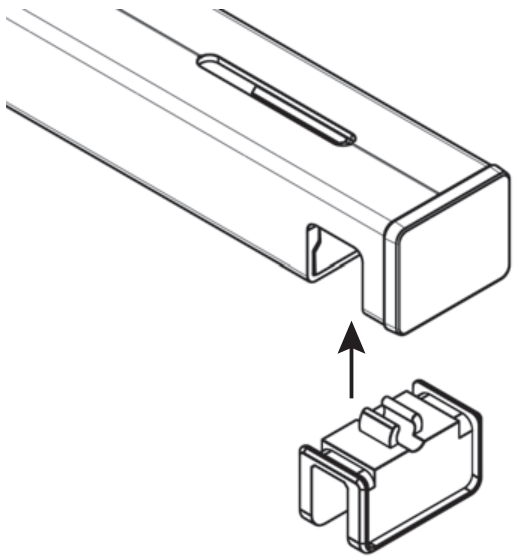

If necessary, swap rubber gasket to suit glass (8mm / 10mm) thickness.

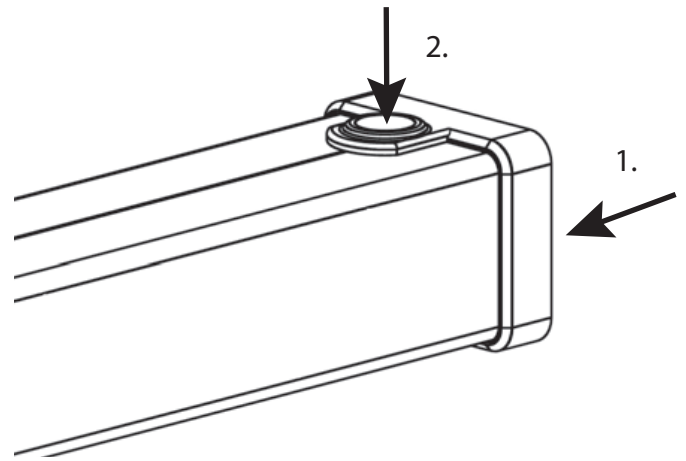

1. Place wall bracket onto cut end of bracing bar.
2. Using wall bracket as a guide, mark top hole position, remove bracket & drill through top section only with 3,5mm drill bit.

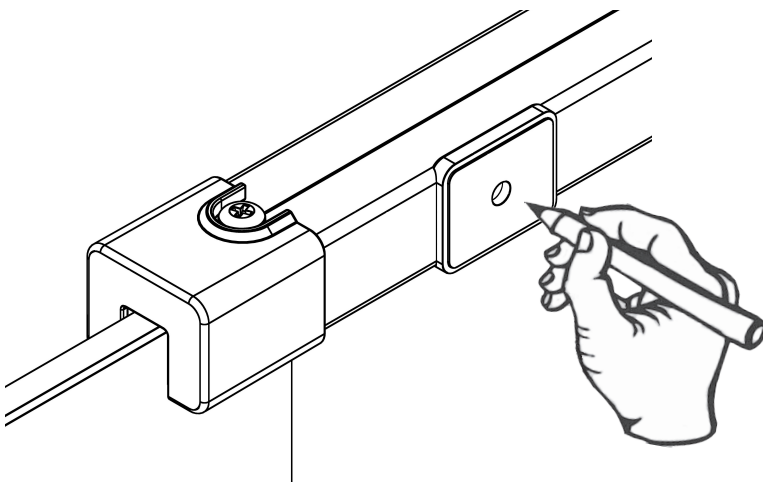

3. Offer 90° joining bracket up to main bracing bar, mark hole position & drill with 3mm drill bit.

4. Fix 90° joining bracket & bracket to fixed bracing with 3,5 x 16mm self tapping screw.

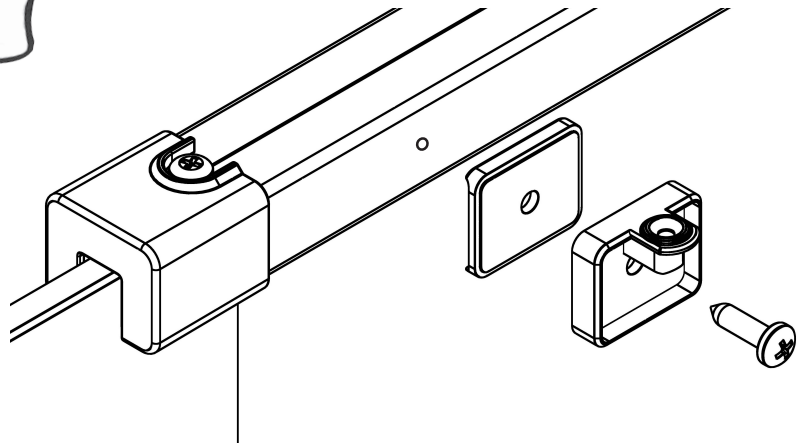

5. Carefully insert bar end into bracket & clamp end onto glass. Fix bar to bracket with M3 screw.

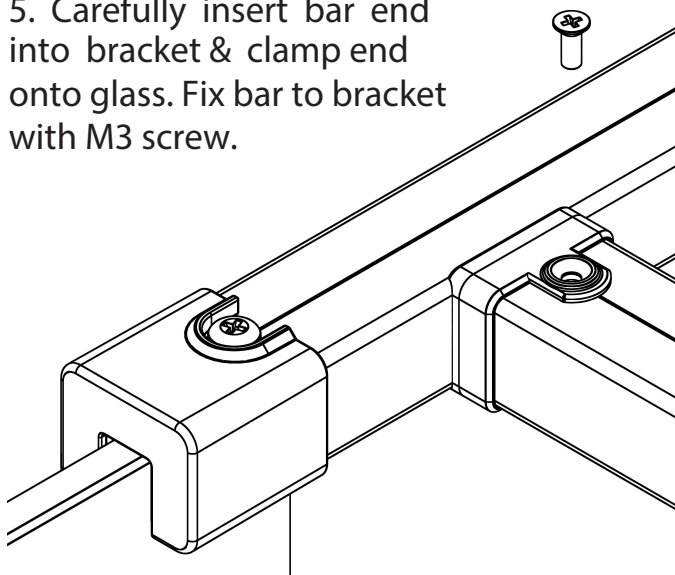

6. Using ball end, locate key in socket screw & tighten clamp as shown.

