

# Bracing Instructions.

(G2C Class to Ceiling Type)

11.23

## Supplied Parts:-

### Ceiling bracket kit (2CB\*\*)

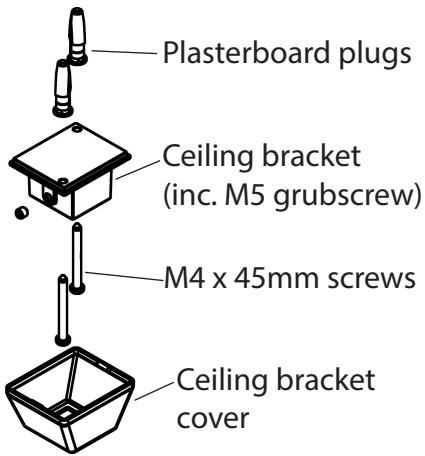

### Ceiling post kit (C2B\*\*)

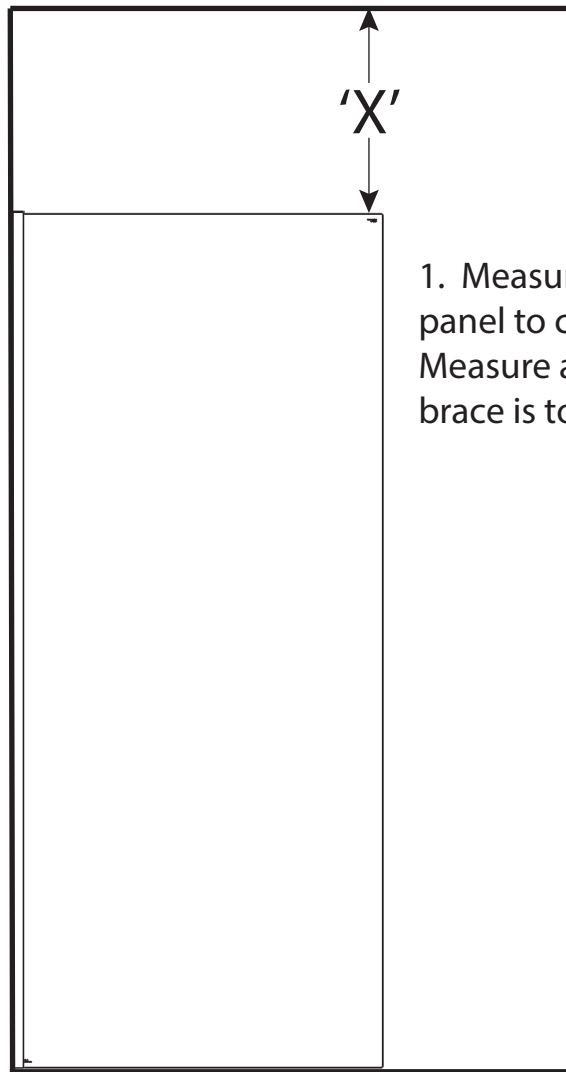
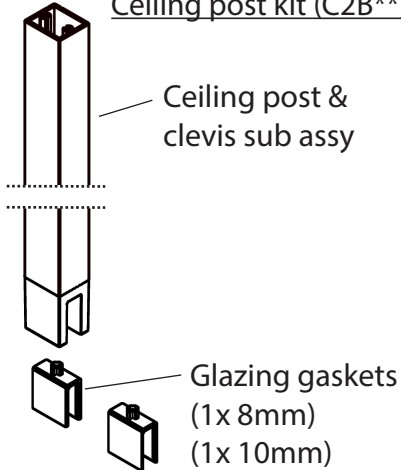

1. Measure from top of glass panel to ceiling (X). Measure at point where ceiling brace is to be fitted.

2. Cut ceiling post. Be sure to cut open end of post NOT clevis end.

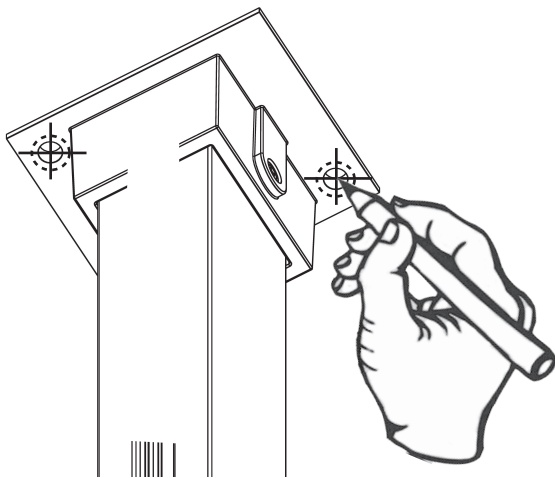
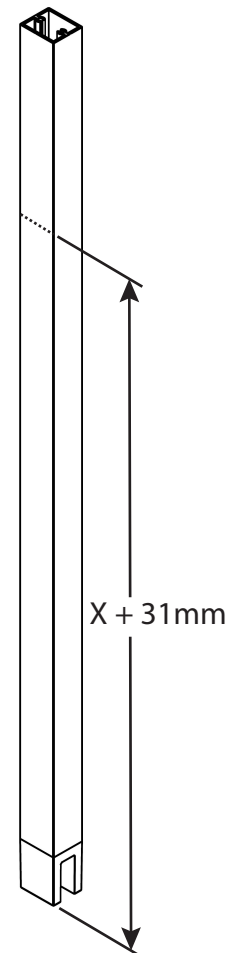

3. Place ceiling bracket onto post and offer onto top of glass, ensure post is plumb, mark through holes in bracket, remove post & bracket, drill marked positions with 6mm drill bit & fit ceiling plugs.

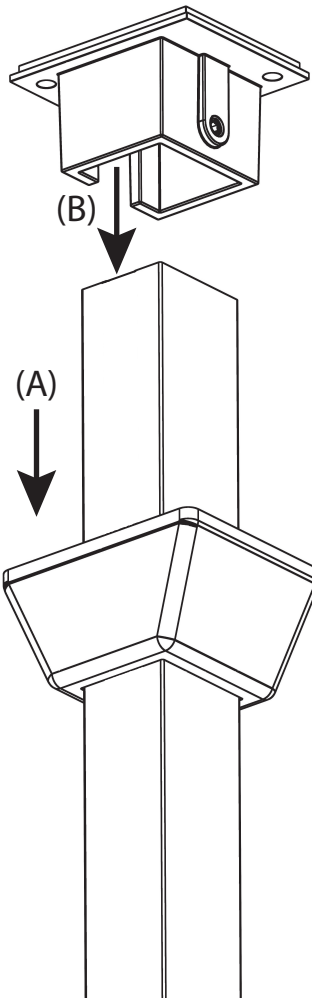

4. Place ceiling bracket cap over ceiling post (A) then place ceiling bracket onto top of post (B).

5. Place ceiling post assembly onto top of glass, line up holes in Ceiling bracket with plugged holes in ceiling & ensure plumb.

6. Fix ceiling bracket to ceiling using M4 x 45mm screws.  
Tighten grub screw in ceiling bracket with 2.5mm allen key.

7. Slide ceiling bracket cap up post until it clips onto ceiling bracket.

